

DC Power Distribution Panel

PN 8023 / PN 3023 / PN 8025 / PN 3025 / PN 8264 / PN 3264
PN 8375 / PN 3375 / PN 8376 / PN 3376 / PN 8377 / PN 3377

Panel Specifications

Material: 0.125" 5052-H32 Aluminum Alloy
Primary Finish: Chemical Treatment per Mil Spec C-5541C
Final Panel Finish: Graphite color 2 part textured Polyurethane
Circuit Breakers: 15 amp AC/DC Magnetic 65V DC/277V AC Maximum
Amperage Rating: All components are sized for 100 Amps of continuous current
Voltage Rating: Panels are rated for 12 or 24 volt DC distribution. Configure your panel with the supplied voltage identification labels.

| | PN | Inches | Millimeters |
|---------------------|-----------|--------------------|---------------|
| Overall Dimensions: | 8023/3023 | 5-1/4 x 7-1/2 | 133.4 x 190.5 |
| | 8025/3025 | 5-1/4 x 3-3/4 | 133.4 x 95.3 |
| | 8264/3264 | 14-3/4 x 7-1/2 | 374.7 x 190.5 |
| | 8375/3375 | 14-3/4 x 4-1/2 | 374.7 x 114.3 |
| | 8376/3376 | 5-1/4 x 11-1/4 | 133.4 x 285.8 |
| Mounting Centers: | 8377/3377 | 10-1/2 x 7-1/2 | 266.7 x 190.5 |
| | 8023/3023 | 4-7/16 x 6-11/16 | 112.7 x 169.9 |
| | 8025/3025 | 4-7/16 x 2-15/16 | 112.7 x 74.6 |
| | 8264/3264 | 13-29/32 x 6-11/16 | 353.2 x 169.9 |
| | 8375/3375 | 13-29/32 x 3-11/16 | 353.2 x 93.7 |
| | 8376/3376 | 4-7/16 x 10-7/16 | 112.7 x 256.1 |
| | 8377/3377 | 9-11/16 x 6-11/16 | 246.1 x 169.9 |

Applicable Standards

- American Boat and Yacht Council (ABYC) Standards and Recommended Practices for Small Craft sections: E-1, E-3, E-9.
- United States Coast Guard 33 CFR Sub Part 1, Electrical Systems.

Document 9467 Rev.1



WARNING

- It is not possible within the scope of these instructions to fully acquaint the installer with all the knowledge of electrical systems that may be necessary to correctly install this product. If the installer is not knowledgeable in electrical systems we recommend that an electrical professional be retained to make the installation.
- If either the panel front or back is to be exposed to water it must be protected with a waterproof shield.
- The panels must not be installed in explosive environments such as gas engine rooms or battery compartments as the circuit breakers are not ignition proof.
- The main positive connection must be disconnected at the battery post to avoid the possibility of a short circuit during the installation of this distribution panel.

Guarantee

Any Blue Sea Systems product with which a customer is not satisfied may be returned for a refund or replacement at any time.

Useful Reference Books

Calder, Nigel, 1996: *Boatowner's Mechanical and Electrical Manual*, 2nd edition, Blue Ridge Summit, PA: TAB Books, Inc.
Wing, Charlie, 1993: *Boatowner's Illustrated Handbook of Wiring*, Blue Ridge Summit, PA: TAB Books, Inc.

Blue Sea Systems Inc.
425 Sequoia Drive
Bellingham, WA 98226 USA

Phone (360) 738-8230
Fax (360) 734-4195
E-mail conductor@blueseasystems.com
www.blueseasystems.com

Installation

1. Disconnect all AC and DC power

Before starting, disconnect the main positive cable from all batteries to eliminate the possibility of a short circuit while installing the distribution panel. Also disconnect the AC shore power cord from the boat to eliminate the possibility of electrocution from AC wiring in the proximity of the DC distribution panel.

2. Apply Voltage Label

All panel components are sized for 12 or 24 Volt systems. Use the labels provided to permanently identify the system voltage and its type (DC) as required by ABYC. Apply the appropriate voltage label to the recessed area on the front of the panel.

3. Select mounting location and cut opening

Select a mounting location which is protected from water on the panel front and back and is not in an area where flammable vapors from propane, gasoline or lead acid batteries accumulate. The circuit breakers used in marine electrical panels are not ignition protected and may ignite such vapors.

Using the panel template provided, make a cut out in the mounting surface where the distribution panel is to be mounted. Do not yet fasten the panel to the mounting surface.

4. Install positive feed wire and negative return

Determine the positive feed (red) and negative return (black or yellow) wire size by calculating the total amperage of the circuits that will be routed through the panel. Blue Sea Systems' electrical panels are rated at 100 amp total capacity. The positive feed wire must be sized for 3% voltage drop at the 100 amp panel rating or the maximum amperage that will be routed through the panel in any particular installation, whichever is less. It is recommended that the positive feed wire be sized for the full panel capacity, which, in most cases, will require at least 2 AWG wire, assuming a 10 foot wire run between the panel and the batteries in 12 volt systems. Refer to the Wire Sizing

Chart for other situations. Remember that the length of the circuit is the total of the positive wire from the power source and the negative wire back to the DC Negative Bus. Be certain that there is a fuse or circuit breaker of the correct size protecting the positive feed wire. In the case of the 24 position panel, jumpers from positive bus to positive bus and from negative bus to negative bus should be the same size as the positive feed and the negative return wires.

5. Install branch circuit wires

Determine the proper wire size for each branch circuit using the guidelines in step 4. Verify that the standard 15 amp circuit breakers installed in the panel are large enough for each branch circuit. Remove and replace with a higher amperage any that are undersized.

Connect the positive (red) branch circuit wires to the load terminals of each circuit breaker.

Connect each negative (black or yellow) branch circuit wire to the DC Negative Bus. DO NOT CONFUSE THE DC NEGATIVE BUS WITH THE DC GROUNDING BUS.

6. Installation of Backlight System

Connect the yellow negative wire to the panel negative bus.

To activate the label lights by the boat's battery switch, connect the red positive wire to the DC panel positive bus.

To activate the label lights by an independent switch or breaker, connect the red positive wire to the load side of the switch or breaker.

7. Optional - install grounding system wire

The grounding wire (bare, green or green with yellow stripe and normally non-current carrying) should not be confused with the negative ground wire (black or yellow and normally current carrying).

Installation (continued)

In *Boatowner's Illustrated Handbook of Wiring*, Charlie Wing identifies three purposes of DC Grounding:

1. Holding conductive housings of low voltage (under 50 volts) DC devices at ground potential by providing a low resistance return path for currents accidentally coming into contact with the device cases.
2. Providing a low resistance return path for electrical current, preventing stray currents that may cause corrosion.
3. Grounding metal electrical cases to prevent emission from inside or absorption from outside of radio frequency noise (RFI).

ABYC requires that grounding wires be sized no smaller than one wire size under that required for current carrying conductors supplying the device to which the grounding wire is connected.

A full treatment of this subject is not possible within the scope of these instructions and there is controversy surrounding the general subject of DC bonding, of which DC grounding is a component. It is suggested that installers not familiar with this subject consult one of the reference books listed elsewhere in these instructions.

8. Apply branch circuit labels and mount panel

Apply a label for each of the branch circuits from the 30 basic labels provided. If the appropriate label is not included, the Extended Label Set of 120 labels may be ordered from your marine supplier (PN 8039). Individual labels are also available from Blue Sea Systems for specific applications. Refer to the label order form for a complete listing of individual labels.

Fasten the panel to the mounting surface using the panel mounting screws supplied with the panel.

9. Testing

Reconnect the main positive cable to the battery terminals and turn the main switch on to supply power to the panel. Turn on all branch circuits and test the voltage at the panel. Compare this voltage to the battery terminal voltage to determine that the voltage drop is within 3%. With all branch circuits still on, test the voltage at one device on each circuit to determine that there is a 3% or 10% drop as is appropriate.

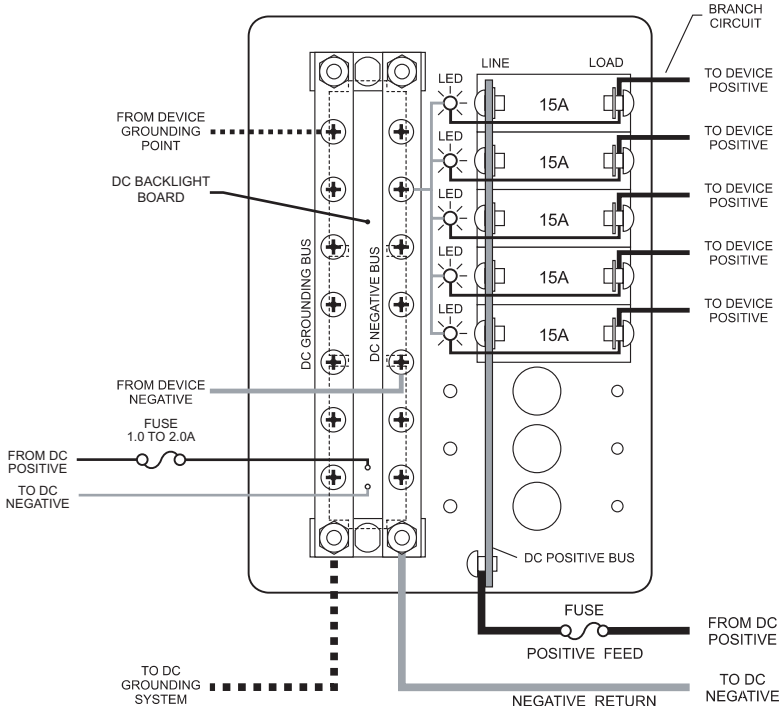

Wiring Diagram
DC Power Distribution Panel
(PN 8023 /PN 3023 shown for reference)

Optional Branch LED's

This Panel is supplied with LED's pre-installed in all optional branch positions. For future expansion of the panels remove the positive leg of the LED from the negative busbar and connect it to the load side of the corresponding branch circuit breaker.

Note

This Blue Sea Systems electrical distribution panel is furnished with 15 amp AC/DC circuit breakers. This rating was selected to minimize the need for removing the panel's circuit breakers and reinstalling different size circuit breakers. As shown in the Wire Sizing Chart included with these instructions, even 16 AWG wire, which is the minimum wire size recommended by ABYC, has an allowable amperage greater than 20 amps. Additionally, it would be rare to have more than 15 amps of current flowing in any one circuit. Therefore, 15 amp circuit breakers will satisfy the vast majority of marine circuit protection situations.

The Purpose of a Panel

There are five purposes of a marine electrical panel:

- Power distribution
- Circuit (wire) protection
- Circuit ON/OFF switching
- Metering of voltage and amperage (In panels with meters)
- Condition Indication (circuit energized)

Related Products from Blue Sea Systems

PanelBack Insulating Covers
High Amperage Fuses and Circuit Breakers for positive feed wires
High Amperage Battery Switches
Terminal Blocks and Common Bus Connectors

Wire Sizing Chart

1. Calculate the maximum sustained amperage of the circuit. Measure the length of the circuit from the power source to the load and back.
2. Does the circuit run in an **engine space** or **non engine space**.
3. Calculate **Famps** (Feet x amps). Multiply circuit length by max. current.
4. Base the wire on either the 3% or 10% **voltage drop**. In general, items which affect the safe operation of the boat and its passengers (running lights, bilge blowers, electronics) use 3%; all other loads use 10%.
5. Starting in the column which has the right **voltage** and **voltage drop**, run down the list until arriving at a value which is greater than the calculated **Famps**. Move left to the **Ampacity** column to verify that the total amperage of the circuit does not exceed the maximum allowable amperage of the wire size for that row. If it does, move down until the wire ampacity exceeds the circuit amperage. Finally, move left to the **wire size** column to select the wire size.

Example

- a. A 12 volt system at 10% drop with a 40' circuit x 45 amps = 1800 Famps. A wire size of 8 is required.

| Wire Size | Wire Ampacity | | Voltage | | 12 | | 24 | | 32 | |
|-----------|---------------|--------|---------|-------|-------|-------|-------|-------|----|-----|
| | non-engine | engine | 3% | 10% | 3% | 10% | 3% | 10% | 3% | 10% |
| 16 | 25.0 | 21.3 | 86 | 288 | 173 | 576 | 230 | 768 | | |
| 14 | 35.0 | 29.8 | 138 | 459 | 275 | 918 | 367 | 1223 | | |
| 12 | 45.0 | 38.3 | 219 | 729 | 437 | 1458 | 583 | 1944 | | |
| 10 | 60.0 | 51.0 | 348 | 1159 | 695 | 2317 | 927 | 3090 | | |
| 8 | 80.0 | 68.0 | 553 | 1843 | 1106 | 3686 | 1474 | 4915 | | |
| 6 | 120.0 | 102.0 | 879 | 2929 | 1757 | 5858 | 2343 | 7811 | | |
| 4 | 160.0 | 136.0 | 1398 | 4659 | 2796 | 9319 | 3727 | 12425 | | |
| 2 | 210.0 | 178.5 | 2222 | 7408 | 4445 | 14815 | 5926 | 19754 | | |
| 1 | 245.0 | 208.3 | 2803 | 9342 | 5605 | 18684 | 7474 | 24912 | | |
| 0 | 285.0 | 242.3 | 3536 | 11788 | 7073 | 23576 | 9430 | 31434 | | |
| 00 | 330.0 | 280.5 | 4457 | 14858 | 8915 | 29715 | 11886 | 39620 | | |
| 000 | 385.0 | 327.3 | 5619 | 18731 | 11239 | 37462 | 14985 | 49950 | | |
| 0000 | 445.0 | 378.3 | 7086 | 23620 | 14172 | 47241 | 18896 | 62988 | | |

Note: For wire with 105°C insulation rating and AWG wire sizes.

Chart courtesy of the West Advisor